

**Note :-** Non-scientific calculator is allowed.

- Q-1 A** What do you understand by foundation of building? And how many components the building has? **7**
- OR**
- Q-1 A** Classify the buildings as per the national building code of India and what is the function of foundation? **7**
- Q-1 B** Draw sketch of panel wall, write primary function of wall, Differentiate between partition wall, party wall, curtain wall and load bearing wall. **7**
- OR**
- Q-1 B** Define door and window. Write down three names of common doors, and Draw sketch of single panel door. **7**
- Q-2 A** Write down at least 10 points which will helps in suitable site selection. **7**
- OR**
- Q-2 A** Write a detailed note on drainage and water supply requirements for buildings and What should be additional provision for hospitals and special risk. **7**
- Q-2 B** What are the types of water supply source and types of distribution system? Explain fire hydrant, requirement of fire hydrant and working of post hydrant. **7**
- OR**
- Q-2 B** Briefly describe any three of them :- Arterial roads, Sub-arterial roads, local roads, streets, pathways. **7**
- Q-3 A** List out the various methods used to determine the resultant of number of forces and Explain any one of them. **7**
- OR**
- Q-3 A** Calculate shear force and bending moment at all important points and draw SFD and BMD. **7**

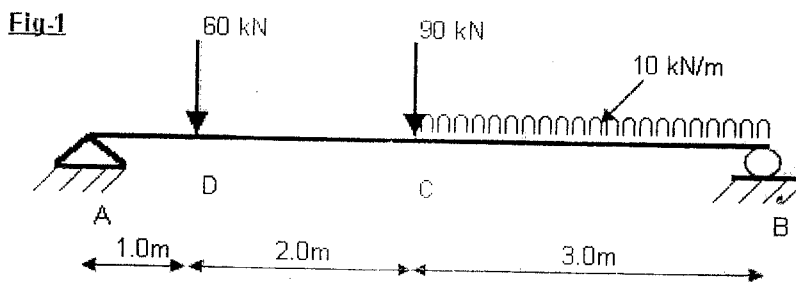

- Q-3 B** What is friction? and explain their types with figure. **7**
- OR**
- Q-3 B** Explain types of support and their reaction. **7**
- Q-4 A** Explain types of beam and their reaction with figure. **7**

(P.T.O)

OR

N 251-2

Q-4 A Find out a center of gravity of a L-section.

7

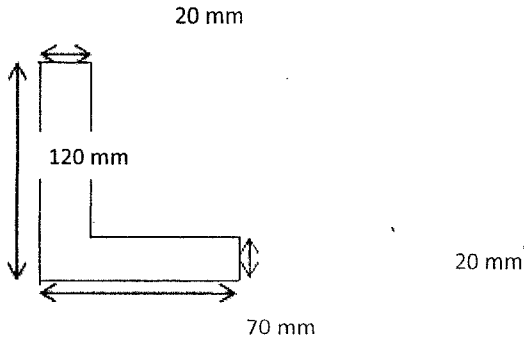

Q-4 B Explain simple strain and their types with neat sketch.

7

OR

Q-4 B A rod is 10 meter long at 20°C. Find the expansion of the rod when the temperature is raised to 60°C. If this expansion is prevented, find the stress in the material. Take  $E = 1.0 \times 10^5 \text{ N/mm}^2$  and  $\alpha = 0.000012 \text{ per}^\circ\text{C}$ .

7

Q-5 Answer the following question.

14

1. Part of super structure located between the ground level and the floor level is known as
  - i. Roof
  - ii. First floor
  - iii. Plinth
  - iv. Footing
2. Institutional building falls under which category?
  - i. Group A
  - ii. Group B
  - iii. Group C
  - iv. Group D
3. The basic function of foundation is to transmit load to
  - i. Super soil
  - ii. Upper soil
  - iii. Sub soil
  - iv. None
4. Floors are horizontal elements for purpose of creating less accommodation. (True/false)
5. Well foundation does not need this requirement.
  - i. Filled with sand
  - ii. Plugged at bottom
  - iii. Complete solid
  - iv. Hollow from inside
6. The soil below timber floor should be covered by R.C.C. of ratio of
  - i. 1:3:6
  - ii. 1:2:4
  - iii. 1:2:3
  - iv. 2:3:4
7. A roof having sloping top surface is called
  - i. Flat roof
  - ii. Terraced roof
  - iii. Pitched roof
  - iv. Curved roof
8. Define Point force and Distributed force.
9. The unit of moment of force is
  - i. N-m
  - ii. N/m
  - iii. N
  - iv. Unit less
10. Define Shear force.
11. Write down the difference between tensile stress and compressive stress.
12. What is Hook's law?
13. When a number of forces are not lie in the same plane they are said to be
  - i. Co-planar forces
  - ii. Non Co-planar forces
  - iii. Concurrent forces
  - iv. Non Concurrent forces
14. Write down the mathematical representation of method of projection.