

B.Sc. (F & S) (Sem.-6) Examination
CC General English
March 2019

Time : 2-30 Hours]

[Max. Marks : 70

Que – 1:(A) Write brief answers of any THREE of the following questions: (09)

- (1) Why did Laura scold Hughie Erskine ?
- (2) What did Baron Hausberg send to Hughie ? And why ?
- (3) Why did the prisoner not escape from the prison ? What complaints did he lodge ?
- (4) What was the hitch in executing the death punishment ?
- (5) What kind of a relationship did George Ramsay share with his brother Tom ?

(B) Write a short note on any ONE of the following: (08)

- (1) The Friendship between Hughie & Alan Trevor
- (2) The Kingdom of Monaco
- (3) George and Tom – a study in contrast

Que-2: (A) Write brief answers of any THREE of the following: (09)

- (1) How do the Long-Nose and his mother become rich ?What are the consequences of this?
- (2) Why was the medical check-up of comrade Long-Nose ordered ?
- (3) Describe in brief the political controversies created by the Long –Nose ?
- (4) What impression did Madame Loisel create at the party ?
- (5) What did Madame Loisel write to Madame Forestier about the necklace ?Why ?

(B) Write a short note on any ONE of the following: (08)

- (1) The World Renowned-Nose, a satire on the psychology of the Masses.
- (2) The character of Brother Long-Nose
- (3) Mathilde

Que-3: Write a Press Report on any ONE: (17)

- (1) A Bus-Truck Collision
- (2) A Major Fire in a residential building
- (3) Republic Day celebration in your college

Que-4:(A) Turn the following sentences into indirect sentences:

(09)

- (1) Mr.Mehta said to Meenaben, " I have already sent you an e-mail about your project".
- (2) Sachin said to Lata, " We are resposnsible citizens of this country and our remarks are very important for the people."
- (3) Amit said to his teacher, " I didn't write the homework because I went to attend a marriage function yesterday."
- (4) "Why don't you follow the traffic rules while driving?" asked the policeman to Seema.
- (5) My father says to my mother, "we are responsible for the bright future of our children."
- (6) The officer said to the youngman, "This is our country and we must respect the constitution of the country"
- (7) The Principal advised the students, "Make a time table for preparation and follow that."
- (8) Mr.Patel said to Mrs.Patel, "You have always supported me in my life and I expect the same in future also."
- (9) The beggar said to the car driver, "we have equal right to use this road and other public facilities."

(B) Choose the appropriate option.

(10)

- 1) What was the name of the girl whom Hughie loved?
 [a] Gerogia Larton [b]Eva Sanders [c]Della Young d]Laura Merton
- 2) What did Mr.Loisel get for his wife one evening?
 [a] a new dress [b]an invitation to a ball [c]film tickets [d] a diamond necklace
- 3) How much money did the Italian Government ask for in order to help with the execution?
 [a] 16,000 francs [b]12,000 francs [c]14,000 francs [d] 10,000 francs
- 4) The Long-Nose was working as _____.
 [a] cook [b]singer [c]politician [d]clerk
- 5) How many writers wrote biographies of Long-Nose and won wealth and acclaim?
 [a] seven [b] twelve [c] nine [d]three
- 6) At what age did George Ramsay plan to retire?
 [a] sixty [b] fifty five [c] sixty five [d] none of the above
- 7) What was Alan trevor?
 [a] singer [b]dancer [c]painter [d]photographer
- 8) Who is the writer of the story 'The Model Millionaire'?
 [a] Oscar Wilde [b]Leo Tolstoy [c] V M Basheer [d] None of these
- 9)How many men made up the Monacon army?
 [a] sixty [b] twenty [c]ninety [d] fifty
- 10) How much time did it take Mathilde and her husband to pay-off their loans?
 [a] one year [b] twelve year [c] ten years [d] thirty six months

B.Sc. (F & S) (Sem.-6) Examination
CC

Fire Safety Risk Assessment & Management

Time : 2-30 Hours]

March 2019

[Max. Marks : 70

Q 1(A) (i) Discuss risk elements and various types of risks those are commonly found in chemical industries. Give their possible consequences. 7

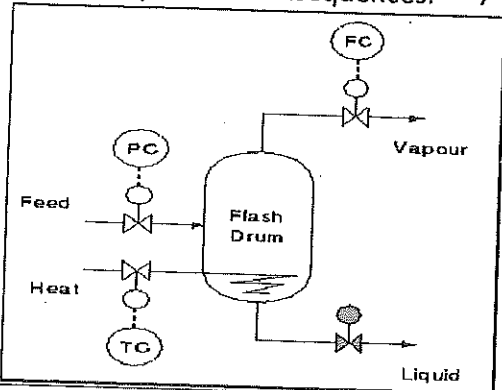

(ii) In the attached diagram one node is given where a flash drum is shown which is connected with feed pipe line and steam pipeline for heat. In the flash drum, liquid and vaporsphases are separated. Temperature controller (TC), Pressure Controller (PC) and Flow controller (FC) with appropriate control valves are shown. Carryout a HAZOP study with respect to High flow in feed pipe line and high temperature in flash drum. Use following sheet. 7

Guide Word	Parameter	Deviation	Causes	Consequences	Actions Taken	Remarks

OR

- (i) Name and describe the various types of basic strategies to control the risks in an organization at the time of risk acceptance and reduction. 7
- (ii) Name various types of hazard identification techniques (HAZID) generally used in a chemical industry. Draw FTA diagram for the fault "No light in the class room".

Q 1(B) MCQs (Any Four) 7

- (i) "Failure Modes and Effects Analysis (FMEA)" belongs to the class of 4
 - a. HAZID Techniques
 - b. HAZOP Analysis
 - c. HIRAC
 - d. None of above

(ii) HAZOP is a systematic and without structured approach using parameter and deviation guidewords. [True / False]

- (iii) "PART OF" is an example of during conducting Hazop:
 - a. Deviation
 - b. Guide word
 - c. Causes
 - d. Consequences

(iv) Select the Fire Barriers:

- a. Fire Protection system
- b. Fire Fighting Equipment
- c. Fire growth
- d. None of the above

(v) Review of fire risk assessment is necessary in case of change in:

- a. Plant
- b. Process
- c. Equipment
- d. Substances
- e. All the above

(vi) A fire event is an occurrence that is related to fire initiation, or fire growth, or smoke spread, or occupant evacuation, or fire department response.

(True /False)

Q 2(A) (i) Describe important steps of FSRA. Why Risk Assessment is carried out?

7

(ii) State the conditions when FSRA should be done. Describe means of escape.

7

OR

(i) What are the means of firefighting? Explain means of giving warning to alert the people at site.

7

(ii) Prepare a risk assessment report of the site of Municipal Fire Station.

Q 2(B) MCQs (Any Four)

7

1. Assembly point is the key aspect of

4

- a. Means of fighting fire
- b. Means of giving warning
- c. Means of escape
- d. None of them

2. Make sure escape routes give access to a safe place at top where people can assemble and accounted for. (True and False)

3. The system to alert people on site is required to be tested :

- a. Once a while
- b. On regular basis
- c. Never
- d. Just after installation

4. Develop and implement an appropriate emergency plan is a part of:

- a. Step 1
- b. Step 2
- c. Step 3
- d. Step 4
- e. Step 5

5. Which will be considered in Step 2 of FSRA:
 - a. People working near the fire
 - b. People working alone in office
 - c. People working alone in the garden
 - d. People driving a car alone
6. "Cooperate and coordinate" should be followed during FSRA at:
 - a. Step 1
 - b. Step 2
 - c. Step 3
 - d. Step 4
 - e. Step 5

Q 3(A) (i) What is "Risk Indexing"? Describe the procedure how to evaluate the same.

7

(ii) Carryout a qualitative fire risk assessment for a multiplex fire using the checklist method. Use an appropriate 5X5 matrix table and the following details:

7

a. Existing Fire Prevention: "Sprinklers"

b. Additional Fire Prevention: No smoking material, Smoke Alarm, Evacuation drills

OR

(i) Give overview of "Quantitative Fire Risk Assessment".

7

(ii) Construct an ETA of a fire scenario considering 40% chances of failure for each with the following fire control systems provided:

7

a. No Combustible Material

b. Sprinkler system

c. Mock drill for evacuation

Q 3(B) MCQs (Any Three)

3

(i) Risk indexing can be used:

a. To calculate Quantitative Risk Assessment

b. To calculate Qualitative Risk Assessment

c. To check consequence of fire

d. For comparison for compliance and equivalency

(ii) The process of ETA comprises of:

a. Identification of potential fire hazards

b. Assessment of their probability and consequence

c. To arrive the risk value

d. All the above

(iii) How severe a fire is can be predicted using:

a. Modeling

b. QRA

c. FMEA

d. ETA

P.T.O.

- (iv) "Risk contouring" is one commonly used method known as:
 - a. Risk presentation technique
 - b. Graphical technique
 - c. Risk estimation technique
 - d. All the above
- (v) "Combustible material" is related to the following during ETA :
 - a. Probability of fire
 - b. Severity of fire
 - c. Control measure
 - d. All the above

Q 4(A) (i) What is Risk Management? Explain characteristics of risk management. 7

(ii) Explain key aspects and functions of risk management. 7

OR

- (i) How a senior manager can contribute in the process of fire safety risk management? 7
- (ii) Describe management structure and the responsibilities. 7

Q 4(B) MCQs (Any Three) 3

- (i) Speculative risk exists when there is change of loss as well as gain. (True / False)
- (ii) When there is change of loss but no change of gain is known as
 - a. Qualitative risk
 - b. Speculative risk
 - c. Quantitative risk
 - d. Pure risk
- (iii) "Peace of mind" belongs to:
 - a. Function of risk management
 - b. Characteristics of risk management
 - c. Key aspect of risk management
 - d. All the above
- (iv) The characteristics of risk management is to control uncertain external developments or events. (True / False)
- (v) Lowering of the cost of risk and improving either profit or operating fund availability is
 - a:
 - a. Function of risk management
 - b. Characteristics of risk management
 - c. Key aspect of risk management
 - d. Feature to manage

✗ ————— ↗

B.Sc. (F & S) (Sem.-6) Examination

CC

Fire Safety Design

March 2019

[Max. Marks : 70]

Time : 2-30 Hours]

Q.No1(a). How many types of sprinkler systems are there ,explain wet system , dry system and pre action system. 7

Q.No1(b). Describe with the help of diagram,Center fed and Grid system ,end fed system used in sprinklers , 7

OR

Q.No1(a). Give the names of sprinklers (at least three)

a) according to its spray (head) b)according to its fixing c)according to its operating principle, and indicate temperature of bulb for mauve, blue and blackcolor. 7

Q.No1(b). What do you understand by temperature rating of QBD .What is the temperature of bulb orange ,yellow and redcolorand describe the working of wet alarm valve. 7

Q.No1(c) Attempt any fourMCQ

1.Up to 500 sprinklers per installation can be provided for this occupancy

L.H, O.H, H.H, VHH

2Which sprinkler system requires high maintenance,

Dry system, wet system, pre action, none

3. This factor is responsible for sprinkler operation

Infra red, uv rays, pressure, temperature

4.This system is preferred for sloping roof tree fed, grid fed, loop fed, end fed

5.The formula for discharge is $Q=kxp$, $Q=K+p$, $Q=K/p$. $Q=kv/p$

6.In this system water can beused for heating and cooling

Tree fed, end fed, loop fed, center fed

Q.No2(a). What do you understand by automatic fire detection ,its principle of operation and types of detectors used in fire services . 7

Q.No2(b). Explain the working of both the types of smoke detectors and draw the fig. of any one detector. 7

OR

Q.No2(a).Write down the types of heat detectors and explain any one of the heat detector with simple figure. 7

Q.No2(b).What are the important locations where the emergency light should be provided.Draw the sign of assembly point and extinguisher. 7

P.T. 0

Q N 344-2

Q.No2(c) MCQ Attempt any 4.

1. Bending of 2 metal strips actuates this detector smoke, beam, flame, heat
2. Emergency light should be available for how much duration 1hr, 2hr, 3hr, 4hr
3. This detector is inserted with a small source of radio active
ionisation, optical, line type, beam type
4. This detector gets disturbed due to solar radiation UV, IR, Heat, smoke
5. Smoke detector has a covering radius of how many meters 4.5, 5.5, 6.5, 7.5,
6. It is visible product of combustion radiation, temperature, heat, flame

Q.No3(a). Give the definition of smoke and which are the two basic methods to keep escape route clear of smoke and explain unsteady clear height and steady clear height with upper layer exhaust.7

Q.No3(b). Explain effect of wind and stack effect responsible for movement of smoke and draw signs of AND gate and OR gate

7

OR

Q.No3(a) What is ventilation, need for ventilation and difference between natural and mechanical ventilation. What is the equipment used for mechanical ventilation

7

Q.No3(b). What is technical ventilation and types of tactical ventilation, explain all in details.7

Q.No3(c) MCQ Attempt any 3

1. Ventilation must preferably be done first from bottom, top, side, end
2. Staircase pressurization comes under which system
Positive, negative, relative, none
3. Tactical ventilation is done by
Before arrival of fire crew, after arrival of crew, done by fire crew, no need of fire crew
4. It is called simplest type of heat detector rate of rise, fixed temp, rate compensated, none
5. To achieve best results water fog stream should cover fog pattern of
50*, 60*, 70*, 80*,

Q.No4(a), Explain CO₂ total flooding system, general properties of CO₂ and its extinguishing properties and safety related issues of CO₂

Q.No4(b). Describe extinguishing properties of DCP. Also explain total flooding system of DCP.7

N 344-3

OR

Q.No4(a). Explain application of CO₂ system, limitations of carbon dioxide, and accessories required for installation of total flooding system. 7

Q.No4(b). Explain the difference between IG 55 and IG 541 and its application and safety requirement and explain NOVEC 1230 properties. 7

Q.No4(c) MCQ Attempt any 3

1. CO₂ is not effective on this material electrical, petrol, diesel, potassium

2. NFPA code for CO₂ system is 10, 11, 12, 13

3. NOVEC 1230 is also called FE 11, FE36, FE 5-1-12, HFC 236

4. In CO₂ flooding system for 34% conc. The qty of CO₂ is

1m³/kg, 1.1m³/kg, 1.11m³/kg, 1.13m³/kg

5. Potassium chloride is also called purple, violet, red, super k

— X —

B.Sc. (F & S) (Sem.-6) Examination

CC

Health, Safety & Environment

March 2019

Time : 2-30 Hours]

[Max. Marks : 70

Q. No. 1 (a) 1 Explain Briefly the key element for health & safety system? Marks 7

Q. No. 1 (a) 2 Outline Aim and objective of health and safety policy? Marks 7

OR

Q. No. 1 (a) 1 Explain briefly which factors influencing health and safety culture? Marks 7

Q. No. 1 (a) 2 Explain briefly which factors influencing health and safety management? Marks 7

Q. No. 1 (b) MCQ Attempt any 4 out of 6. Marks 4

1 Definition of Risk?

2 Definition of Near miss?

3 Definition of occupational Accident?

4 Definition of Health and safety culture?

5 Definition of Environment protection?

6 Definition of Health

Q. No. 2 (a) 1 Briefly explain Attitude, Aptitude and Motivation? Marks 7

Q. No. 2 (a) 2 Briefly explain the nature and subject of safety philosophy? Marks 7

OR

Q. No. 2 (a) 1 Explain Domino Theory of Accident Causation? Marks 7

Q. No. 2 (a) 2 What do you mean by Aptitude? Write down the classification of Aptitude? Marks 7

Q. No. 1 (b) MCQ Attempt any 4 out of 6. Marks 4

1 Definition of Ergonomics?

2 Write Down two production ergonomics?

3 Write Down two product ergonomics?

4 Write Down two vehicle ergonomics?

5 Write Down two work design ergonomics?

6 Write Down two points for need of safety philosophy?

Q. No. 3 (a) 1 Briefly explain Thermal pollution? Marks 7

Q. No. 3 (a) 2 Briefly explain industrial pollution? Marks 7

OR

Q. No. 3 (a) 1 Write a short note on CETP PLANT? Marks 7

Q. No. 3 (a) 2 Briefly Explain Ozone depletion? Marks 7

N379-2

Q. No. 3 (b) MCQ Attempt any 3 out of 5. Marks 3

- 1 Write a types of air pollutant
- 2 What is SMOG?
- 3 WhAt is W.H.O?
- 4 What are the auditory effects of noise pollution?
- 5 What is G.H.G?

Q. No. 4 (a) 1 Explain Briefly the need of EMS audit? Marks 7

Q. No. 4 (a) 2 List out the procedure, steps of environment audit & explain follow up review? Marks 7

OR

Q. No. 4 (a) 1 List out the objective for environment audit & explain it in Brief? Marks 7

Q. No. 4 (a) 2 Write a short note in reduce, reuse, recycle of Waste management? Marks 7

Q. No. 4 (b) MCQ Attempt any 3 out of 5. Marks 3

- 1 What is oil emulsification?
 - 2 What is NFPA?
 - 3 OISD Stands for-----?
 - 4 ASOSAI Stands for-----?
 - 5 What is carbon sequeatration?
-